



F 1000

Hamburgatrice / Patty former machine



1

OPTIONAL

1



OPTIONAL

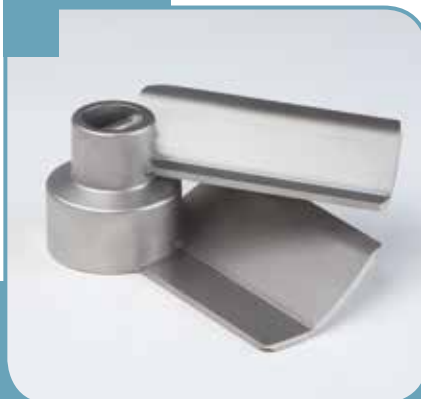

DOTAZIONI DI SERIE

- Velocità fissa
- Produzione 1560 pz/h con forma singola
- Produzione 3120 pz/h con forma doppia
- 1 stampo
- Racla in alluminio
- Nastro standard 390 mm
- Contenitore prodotto 16 lt / 10 kg
- Nessuna chiave per smontaggio parti

OPTIONAL

- Interfogliatore
- Racla Inox
- Pulitore pneumatico
- Nastro lungo 900 mm
- Carrello di supporto con ruote
- Pedale

STANDARD EQUIPMENT

- *Fixed speed*
- *High productivity: 1560 patties per hour with single shape*
- *High productivity: 3120 patties per hour with double shape*
- *1 drum*
- *Alluminium paddle*
- *Standard conveyor belt 390 mm*
- *Hopper 16 lt / 10 kg*
- *No specific dismantling tools*

OPTIONAL

- *Paper attachment*
- *Stainless steel paddle*
- *Pneumatic wire cleaner*
- *Longer conveyor belt 900 mm*
- *Support table with wheels*
- *Foot switch*

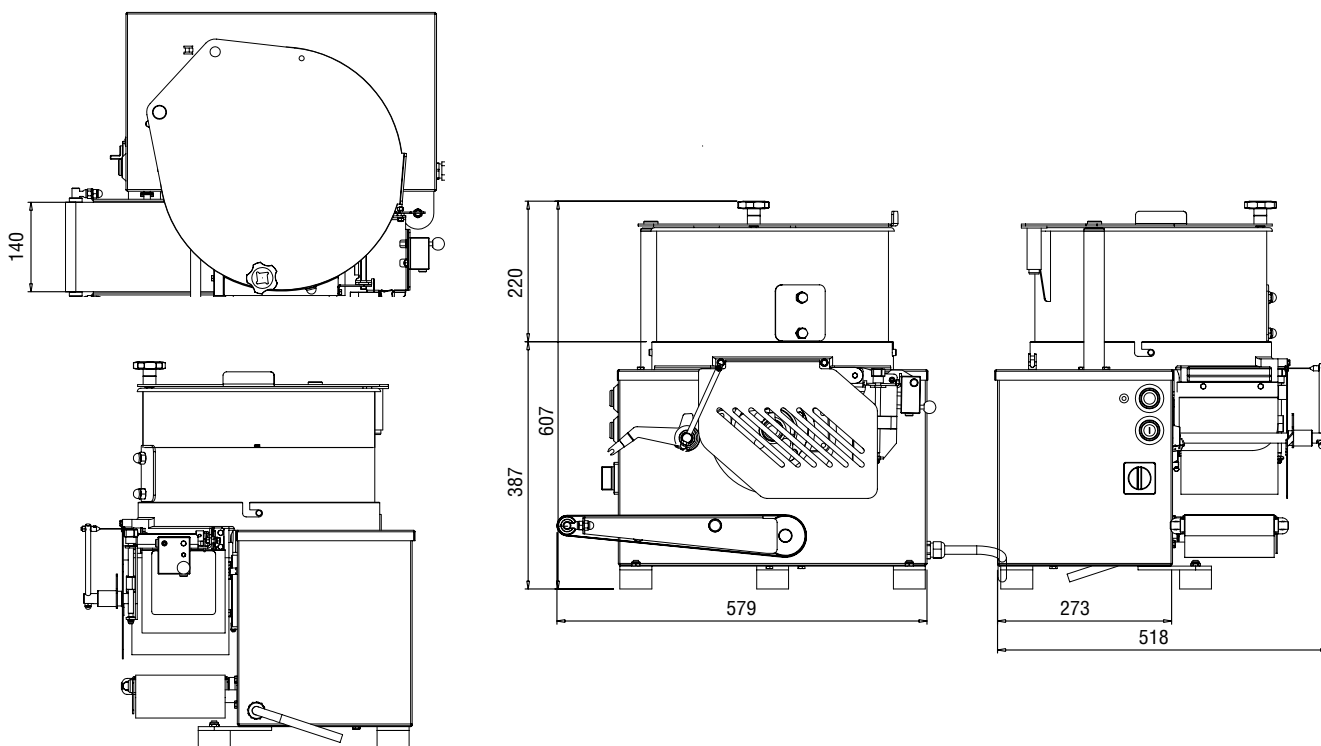

SPECIFICHE TECNICHE / TECHNICAL SPECIFICATION

Motore	<i>Motor</i>	0,55 kw
Velocità	<i>Speed</i>	1300 rpm
Diametro foglio carta	<i>Paper dimension</i>	135 x 135 mm
Diam. max ottenibile stampo singolo circolare	<i>Shape - max diam - single shape</i>	130 mm
Diam. max ottenibile stampo doppio circolare	<i>Shape - max diam - double shape</i>	55 mm
Peso netto	<i>Net weight</i>	57 kg
Peso imballato	<i>Packed weight</i>	75 kg
Dimensioni imballo legno	<i>Wooden crate</i>	770 x 700 x 750 mm